

XTN1 100

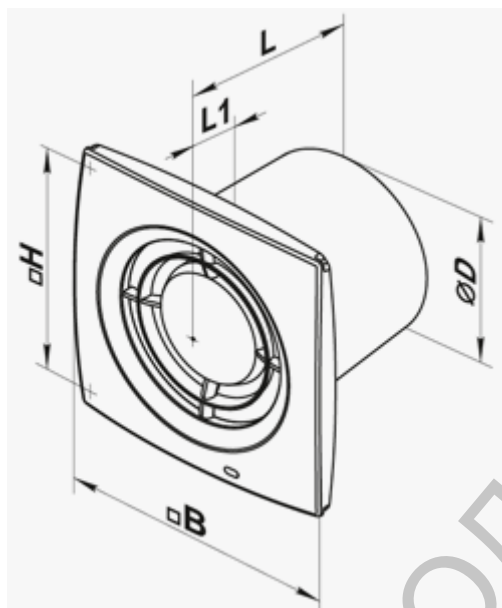

Parameter	Value	Unit	
	Voltage	220-240	
Frequency	50	Hz	
Power	14	W	
	0,014	kW	
Extract capacity	99	m ³ /h	
	58,311	CFM	
	27,522	l/s	
	0,02752	m ³ /s	
	1653,3	l/m	
Current	0.085	A	
R.P.M.	2300	min ⁻¹	
Noise level at 3 m	33	dBA	
Weight	0.6	kg	
Index of protection	IP 34	class	
Dimension of connection pipe	100	mm	

XTN1 100



Sizes	ØD	B	H	L	L1
mm	100	152	120	108	11.5

Ташев-Галвинг ООД
www.tashev-galving.com